



Presents

Diagnosing Electrical Problems on Today's Motor Vehicles **PART 2**

© A.T.T.S. Inc. 2015 - 2019

22



Your Instructor For This Class

"G" Jerry Truglia

- **National Trainer, ASE World Class, Master: Auto, Truck, School Bus, L1, L3, CNG and...**
- **ATTP Master Instructor, New York State, CT and New Jersey**
- **STS (Service Technician Society) 2003 President**
- **TST (Technicians Service Training) Founder and President**
- **Author / Co Author/ Technical adviser on 25 plus books including
OBD II and Mode 6, and Understanding and Diagnosing Hybrid Vehicles**
- **Published articles for multiple newsletters, and magazines**
- **Picked as one of the Top Instructors in the country by EPA & SAE**
- **Numerous Radio, TV, Internet, and SAE Video appearances**
- **PTEN, MotorAge and TST Webcast Instructor**
- **Motor Magazine Top 20 award winner**
- **Provider of OBD II Training for 13 states, Ontario Canada and the US EPA**
- **Guest speaker at SAE Congress, IM Solutions and Clean Air Conference**

© A.T.T.S. Inc. 2015 - 2019

23

AOV

Amps =

Ohms =

Volts =

© A.T.T.S. Inc. 2015 - 2019

24



Project #1

Electric Light & Switch

OBJECTIVE: To show how electricity is turned "ON" or "OFF" with a switch.

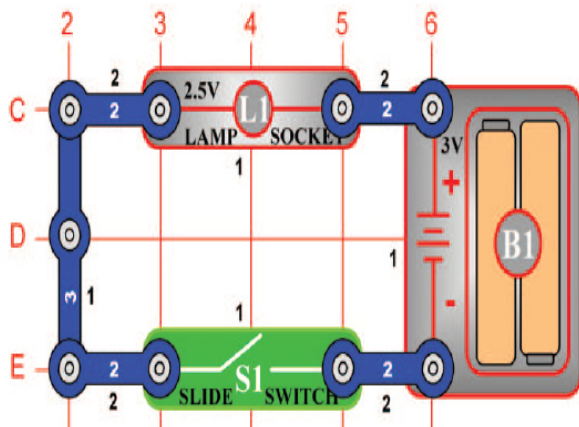

Build the circuit shown on the left by placing all the parts with a black 1 next to them on the board first. Then, assemble parts marked with a 2. Install two (2) "AA" batteries (not included) into the battery holder (B1) and screw the bulb into the lamp socket (L1) if you have not done so already.

When you close the slide switch (S1), current flows from the batteries through the lamp and back to the battery through the switch. The closed switch completes the circuit. In electronics this is called a closed circuit. When the switch is opened, the current can no longer flow back to the battery, so the lamp goes out. In electronics this is called an open circuit.

© A.T.T.S. Inc. 2015 - 2019

25



Project #2

DC Motor & Switch

OBJECTIVE: To show how electricity is used to run a Direct Current (DC) Motor.

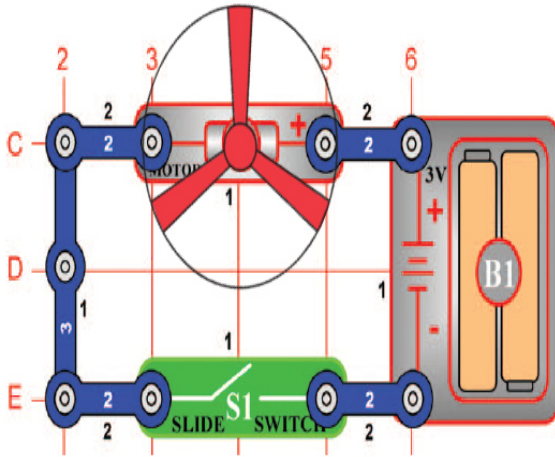

Build the circuit shown on the left by placing all the parts with a black 1 next to them on the board first. Then, assemble parts marked with a 2.

When you close the switch (S1), current flows from the batteries through the motor making it rotate. Place the fan blade on the motor shaft and close the slide switch (S1). The motor will rotate forcing the fan blade to move air past the motor.

In this project, you changed electrical power into mechanical power. DC motors are used in all the battery powered equipment requiring rotary motion, such as a cordless drill, electric tooth brush, and toy trains that run on batteries just to name a few. An electric motor is much easier to control than gas or diesel engines.



WARNING: Moving parts. Do not touch the fan or motor during operation.

© A.T.T.S. Inc. 2015 - 2019

26



Project #5

Lamp & Fan in Series

OBJECTIVE: To show how a lamp can indicate when a fan is running.

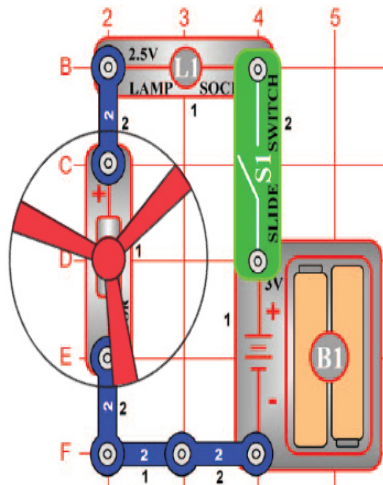

Build the circuit shown on the left by placing all the parts with a black 1 next to them on the board first. Then, assemble parts marked with a 2. Finally, place the fan blade on the motor.

When you close the slide switch (S1), the fan will spin and the light should turn on. The fan will take a while to start turning due to inertia. Inertia is the property that tries to keep a body at rest from moving and tries to keep a moving object from stopping.

The light helps protect the motor from getting the full voltage when the switch is closed. Part of the voltage goes across the light and the rest goes across the motor. Remove the fan and notice how the light gets dimmer when the motor does not have to spin the fan blade.



WARNING: Moving parts. Do not touch the fan or motor during operation.

© A.T.T.S. Inc. 2015 - 2019

27



Project #6

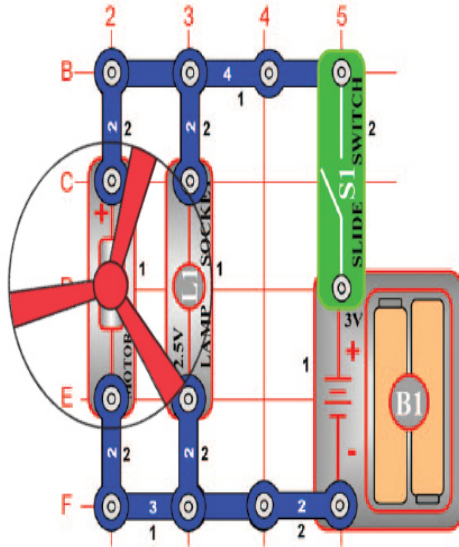

© A.T.T.S. Inc. 2015 - 2019

Lamp & Fan in Parallel

OBJECTIVE: To show how an indicator light can be connected without affecting the current in the motor.

Build the circuit shown on the left.

When you close the slide switch (S1), both the fan and the light should turn on. The fan will take a while to start turning due to inertia. In this connection, the lamp does not change the current to the motor. The motor should start a little faster than in Project #5.

Remove the fan and notice how the light does not change in brightness as the motor picks up speed. It has its own path to the battery.

WARNING: Moving parts. Do not touch the fan or motor during operation.

28



Project #7

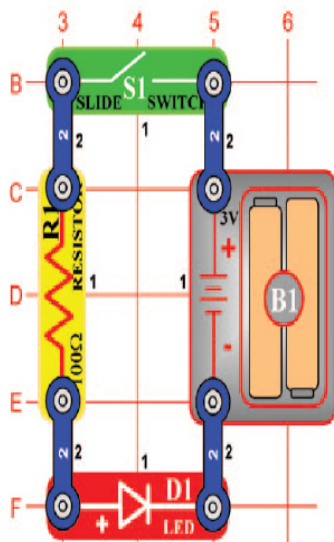

© A.T.T.S. Inc. 2015 - 2019

Light Emitting Diode

OBJECTIVE: To show how a resistor and LED are wired to emit light.

Build the circuit shown on the left by placing all the parts with a black 1 next to them on the board first. Then, assemble parts marked with a 2.

When you close the slide switch (S1), current flows from the batteries through the switch, through the resistor, through the LED (light emitting diode) and back to the battery. The closed switch completes the circuit. The resistor limits the current and prevents damage to the LED. NEVER PLACE AN LED DIRECTLY ACROSS THE BATTERY! If no resistor is in the circuit, the battery may push enough current through the LED to damage the semiconductor that is used to produce the light. LEDs are used in all types of electronic equipment to indicate conditions and pass information to the user of that equipment.

Can you think of something you use everyday that has an LED in it?

29



Project #8

One Direction for LED

OBJECTIVE: To show how electricity can only pass in one direction through an LED.

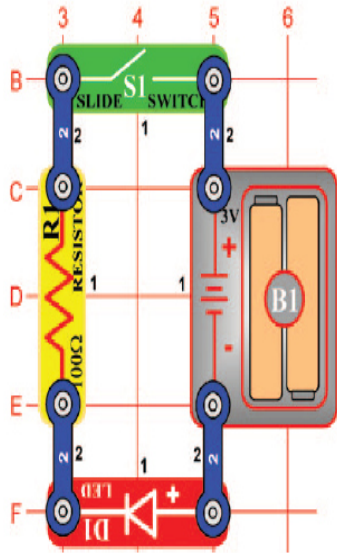

Rebuild the circuit used in Project #7 but put the LED in as shown on the left.

When you close the slide switch (S1), current should flow from the batteries through the resistor and then through the LED. When current flows through an LED, it lights up. Since the LED is in backwards, current cannot flow. The LED is like a check valve that lets current flow in only one direction.

In this project, you changed the direction for current through the LED. An electronic component that needs to be connected in one direction is said to have polarity. Other parts like this will be discussed in future projects. Placing the LED in backwards does not harm it because the voltage is not large enough to break down this electronic component.

© A.T.T.S. Inc. 2015 - 2019

30

DC Voltage

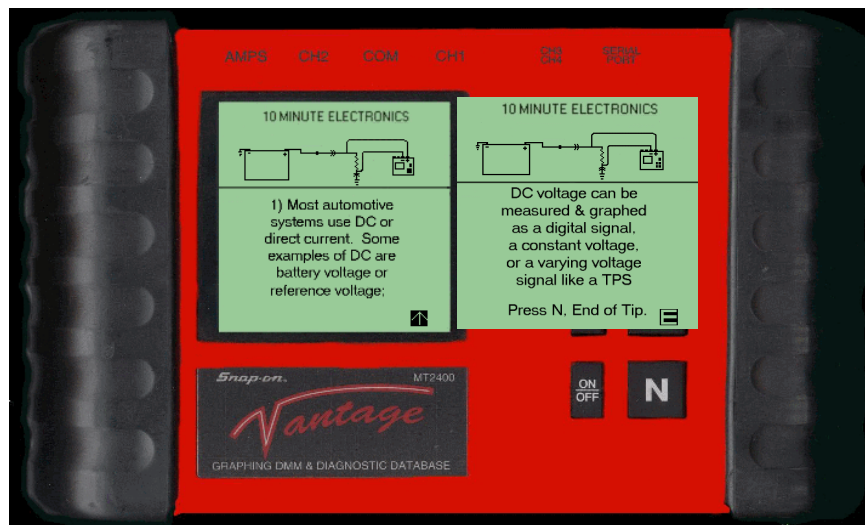

© A.T.T.S. Inc. 2015 - 2019

31

Duty Cycle

10 MINUTE ELECTRONICS
50% DUTY CYCLE

Most automotive Duty Cycle specs refer to the circuit's on-time;

10 MINUTE ELECTRONICS
50% DUTY CYCLE

1) Duty cycle is the length of time a circuit is on or off & is expressed in percentage (%);

10 MINUTE ELECTRONICS
50% DUTY CYCLE

On-time may refer to either the high or low portion of the waveform depending if circuit is power side or ground side controlled. Press N, End of Tip.

Snap-on MT2400
Vantage
GRAPHING DMM & DIAGNOSTIC DATABASE

ON OFF N

© A.T.T.S. Inc. 2015 - 2019

32

Frequency HZ

10 MINUTE ELECTRONICS
1 SEC 1 SEC 1 SEC 1 SEC

Frequency is measured in Hz (Hertz)=Cycles per Second. Therefore, the signal above has a frequency of 1 Hz (One Hertz);

10 MINUTE ELECTRONICS
1 SEC

This signal has a higher frequency. It is repeating four times per second. This signal has a frequency of 4 Hz;

1) Frequency is number of times a cycle repeats itself. The cycle above is repeating every second;

10 MINUTE ELECTRONICS

You can also measure frequency on a histogram. By graphing frequency you can quickly see any drop out without Press N, End of Tip.

Snap-on MT2400
Vantage
GRAPHING DMM & DIAGNOSTIC DATABASE

ON OFF N

© A.T.T.S. Inc. 2015 - 2019

33

Voltage Drop

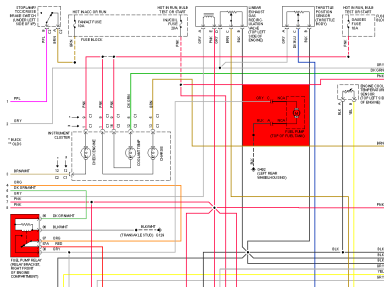
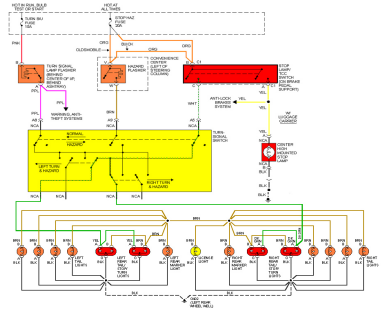

© A.T.T.S. Inc. 2015 - 2019